

*Fairfax County, Virginia*

# Typical Deck Details

Based on the 2009 International Residential Code

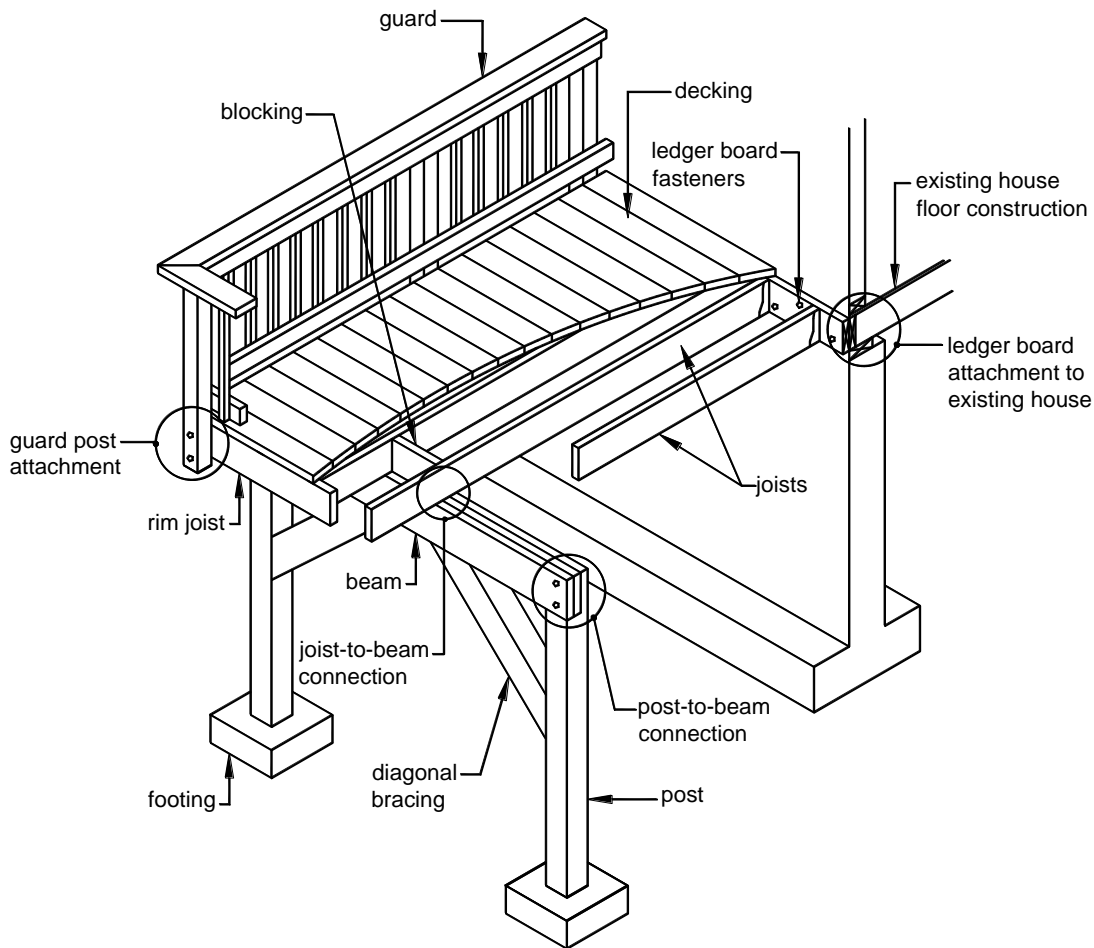


The design details in this document apply to residential decks only. Framing requirements are limited to single span, single level decks. Construction must not deviate from the details herein unless prior approval is obtain by the county. A copy of this document must be on the job site and available during each required inspection.



# Fairfax County, Virginia Typical Deck Details

## CONTENTS



Section	Page	Section	Page
1 General Notes .....	3	10 Ledger Board Fasteners .....	10
2 Decking .....	3	11 Framing at Chimney/Bay Window .....	12
3 Joists .....	4	12 Free-Standing Decks .....	12
4 Beams .....	5	13 Lateral Support .....	13
5 Joist-to-Beam Connection .....	6	14 Guards .....	15
6 Joist Hangers .....	6	15 Stairs .....	16
7 Posts .....	7	16 Safety Glazing .....	19
8 Footings .....	7	17 Complete Your Deck .....	20
9 Ledger Attachments .....	8		

Fairfax County is committed to a policy of nondiscrimination in all county programs, services and activities. To request this information in an alternate format, call Customer and Technical Support Center at 703-222-0801, TTY 711 or write Department of Public Works and Environmental Services, Suite 230, 12055 Government Center Parkway, Fairfax, VA 22035-5506. Please allow at least seven working days for preparation of material.

## SECTION 1: GENERAL NOTES

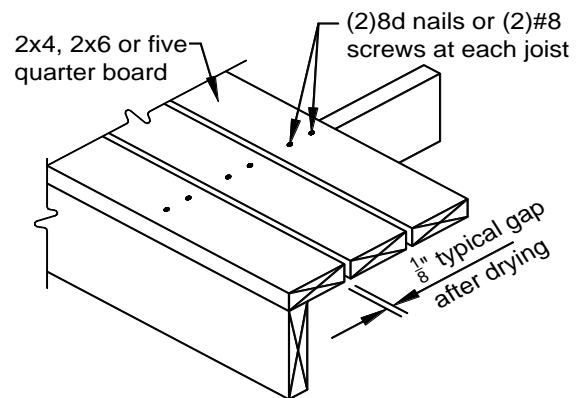
1. Lumber shall be preservative-treated, southern pine, grade #2 or better. Lumber in contact with the ground shall be rated as “ground-contact;” please note: not all treated lumber is rated for ground contact.
2. Wood-plastic composites are materials composed of bound wood and plastic fibers used typically as decking and elements of a guard. Permissible as noted in this document, wood-plastic composites must bear a label indicating its performance criteria and compliance with ASTM D 7032.
3. When using a wood-plastic composite, exercise caution as some composite members do not have the same capacity as their equivalent wood sizes.
4. Nails shall be threaded, ring-shanked or annular grooved. A 1/8-inch pilot hole is recommended for all toe-nailing locations.
5. Fasteners shall be hot-dipped galvanized, stainless steel or approved for use with preservative-treated lumber.
6. Carriage-bolts may be substituted where through-bolts are specified provided carriage-bolt washers (with square holes) are installed at the bolt head.
7. Hardware, e.g., joist hangers or post anchors, shall be stainless steel or galvanized with 1.85 ounces of zinc per square foot (G-185 coating). Look for product lines such as “Zmax,” “Triple Zinc” or “Gold Coat.”
8. Decks with a floor area greater than 20 square feet shall have an electrical outlet along the perimeter of the deck and within 6.5 feet of the floor.
9. Decks constructed in accordance with these details are not approved for privacy screens, planters, built-in seating or hot tubs.
10. Information regarding permit, plan review and inspection requirements can be found in the “Decks” publication at [fairfaxcounty.gov/decks](http://fairfaxcounty.gov/decks).
11. Publication “DCA6” from the American Wood Council is considered equivalent to these details and can be used to obtain a permit in Fairfax County. Go to [awc.org](http://awc.org) to learn more or to download “DCA6.”

## SECTION 2: DECKING

**Approved material.** Wood or wood-plastic composite decking shall be installed in accordance with the requirements below.

- Decking shall be wood 2x4, 2x6 or five-quarter board (span-rated decking) and wood-plastic composite sizes per manufacturer.
- Wood decking may be placed at an angle of 45 to 90 degrees to the joists and attached per FIGURE 1. If wet, place decking with no gap so after drying a 1/8-inch gap is created.
- Each wood decking member shall bear upon a minimum of three joists or intermediate blocking between joists.
- Placement and attachment of wood-plastic composites shall be per manufacturer's instructions.
- Wood-plastic composite's label and installation instructions must be made available to the inspector.

**Plastic decking.** Plastic or PVC decking, not considered a wood-plastic composite, may be substituted only when the product has a valid evaluation report (see FIGURE 28) from an accredited listing agency and is capable of resisting a live load of 40 pounds per square feet. Installation shall be in conformance with the evaluation report and the manufacturer's instructions which must be made available to the inspector. For a list of approved products, go to [fairfaxcounty.gov](http://fairfaxcounty.gov) and search on “structural plastics.”

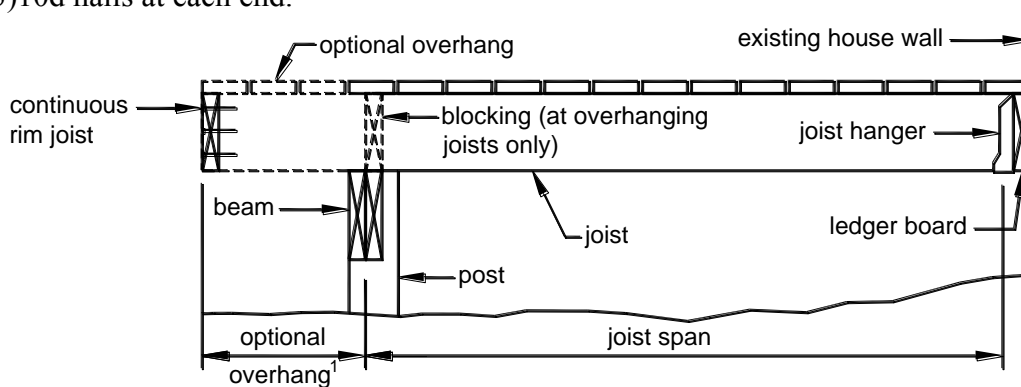


**FIGURE 1: TYPICAL DECKING**

## SECTION 3: JOISTS

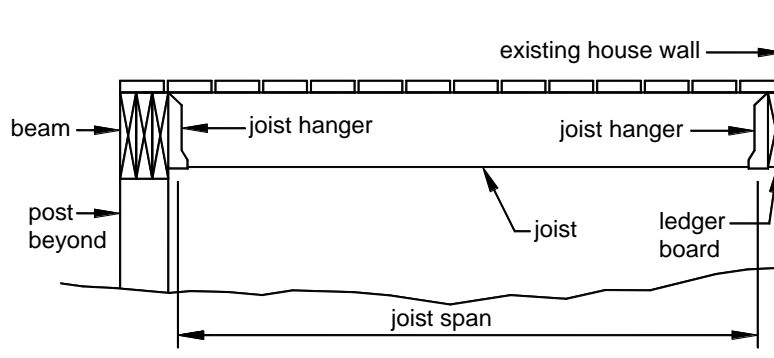
Joists shall be designed in accordance with the requirements below.

- Joist span length is measured between the centerline of bearing at each joist end and does not include the overhangs. Use TABLE 1 to determine your joist size based on span length and joist spacing.
- See FIGURES 2 through 4 for joist span types.
- Joists may overhang past the center of the beam up to one-fourth of the actual joist span.
- Provide full-depth 2x blocking between overhanging joists above beam locations; toe-nail with (3)10d nails at each end. **Exception:** blocking may be omitted if the overhang is less than or equal to 2 feet.
- Attach a continuous rim joist or blocking at the joist ends as shown in FIGURES 2 and 4. Attach rim joist to the end of each joist with (3)10d nails or (3)#10 by 3-inch wood screws. Attach blocking with (3)10d nails at each end.

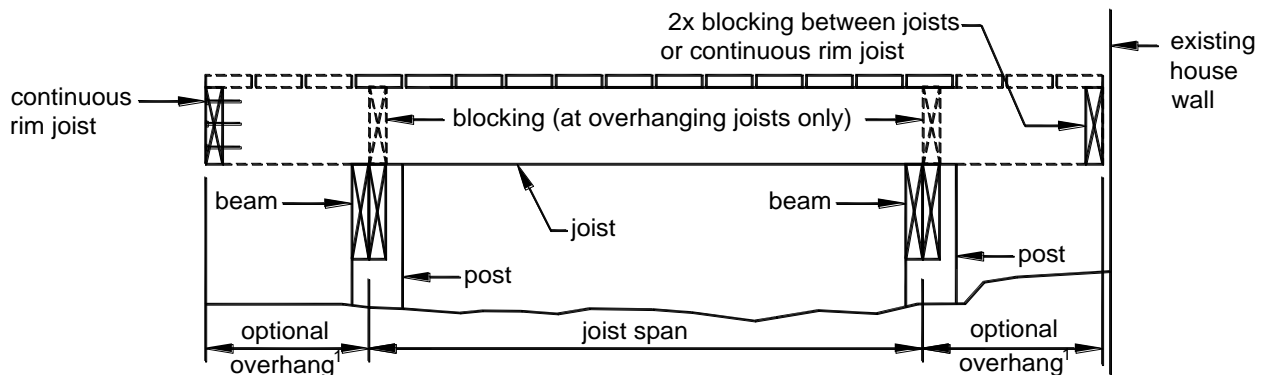


<sup>1</sup> The maximum length of the overhang is equal to one-fourth of the actual joist span length (0.25 x joist span).

**FIGURE 2: JOISTS WITH DROPPED BEAM – DECK ATTACHED AT HOUSE**



**FIGURE 3: JOISTS WITH FLUSH BEAM – DECK ATTACHED AT HOUSE**



<sup>1</sup> The maximum length of the overhang is equal to one-fourth of the actual joist span length (0.25 x joist span).

**FIGURE 4: JOISTS WITH TWO DROPPED BEAMS/FREE-STANDING DECK**  
(See Page 12 for more information.)

**TABLE 1: MAXIMUM JOIST SPAN LENGTH<sup>1</sup>**

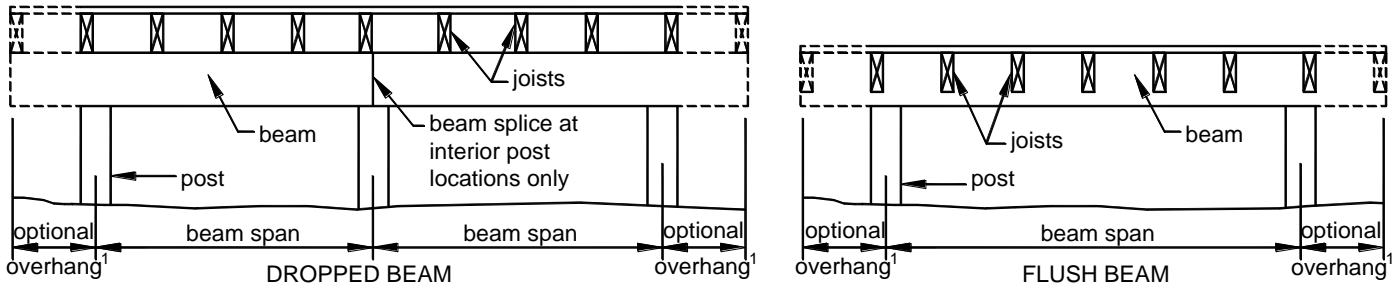
JOIST SPACING (on center)	JOIST SIZE	WITHOUT OVERHANG	WITH OVERHANGS
12"	2x6	9'-11"	6'-8"
	2x8	13'-1"	10'-1"
	2x10	16'-2"	14'-6"
	2x12	18'-0"	18'-0"
16"	2x6	9'-0"	6'-8"
	2x8	11'-10"	10'-1"
	2x10	14'-0"	14'-0"
	2x12	16'-6"	16'-6"
24"	2x6	7'-7"	6'-8"
	2x8	9'-8"	9'-8"
	2x10	11'-5"	11'-5"
	2x12	13'-6"	13'-6"

<sup>1</sup>Spans are based on 40 PSF live load, 10 PSF dead load, southern pine #2, normal loading duration, wet service conditions and deflections of  $\Delta = \ell/360$  for main span and  $\ell/180$  for overhang with a 220 lbs. point load.

**SECTION 4: BEAMS**

Beams shall be designed and assembled in accordance with the requirements below.

- As shown in FIGURE 5, beam span length is measured between the centerlines of two adjacent posts and does not include the overhangs.
- Beam size is determined using TABLE 2. Flush beams shall be greater than or equal to the joist depth.
- Beams may overhang past the center of the post up to one-fourth of the actual beam span as shown in FIGURE 5.
- The plies of the beam shall be assembled in accordance with FIGURE 6.
- Preservative-treated glulam beams are permissible for spans longer than those shown in TABLE 2. However, a design and plan submission to the county is required during the permit application process.



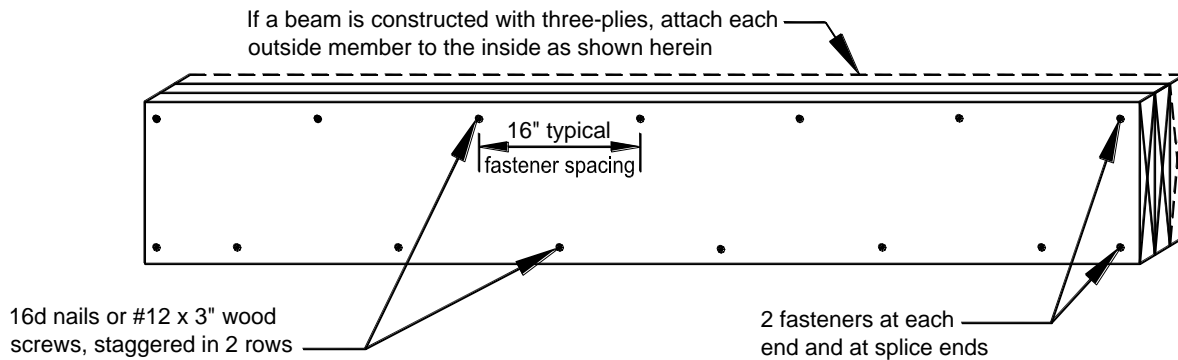
<sup>1</sup> The maximum length of the overhang is equal to one-fourth of the actual beam span length (0.25 x beam span).

**FIGURE 5: BEAM TYPES**

**TABLE 2: MAXIMUM BEAM SPAN LENGTH<sup>1</sup>**

Joist Span less than or equal to:	(number of plies) Beam Size							
	(2)2x6	(2)2x8	(2)2x10	(2)2x12	(3)2x6	(3)2x8	(3)2x10	(3)2x12
6'	6'-11"	8'-9"	10'-4"	12'-2"	8'-2"	10'-10"	13'-0"	15'-3"
8'	5'-11"	7'-7"	9'-0"	10'-7"	7'-5"	9'-6"	11'-3"	13'-3"
10'	5'-4"	6'-9"	8'-0"	9'-5"	6'-8"	8'-6"	10'-0"	11'-10"
12'	4'-10"	6'-2"	7'-4"	8'-7"	6'-1"	7'-9"	9'-2"	10'-9"
14'	4'-6"	5'-9"	6'-9"	8'-0"	5'-8"	7'-2"	8'-6"	10'-0"
16'	4'-3"	5'-4"	6'-4"	7'-6"	5'-3"	6'-8"	7'-11"	9'-4"
18'	4'-0"	5'-0"	6'-0"	7'-0"	5'-0"	6'-4"	7'-6"	8'-10"

<sup>1</sup>Spans are based on 40 PSF live load, 10 PSF dead load, southern pine #2, normal loading duration, wet service conditions and deflections of  $\Delta = \ell/360$  for main span and  $\ell/180$  for overhang with a 220 lb. point load.

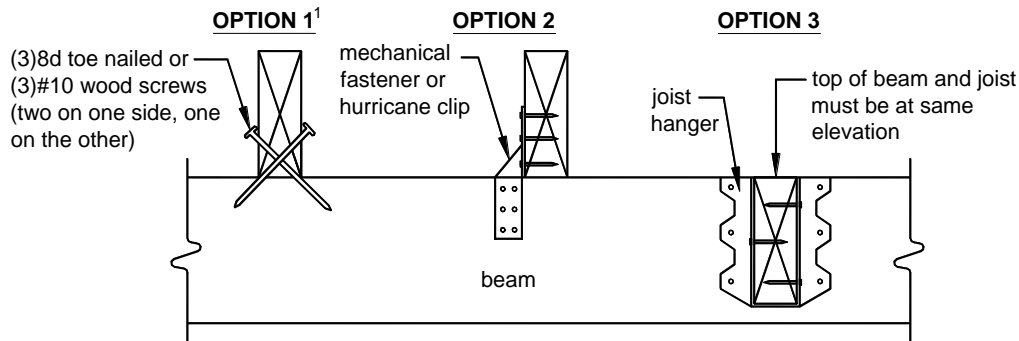


**FIGURE 6: BEAM ASSEMBLY**

## SECTION 5: JOIST-TO-BEAM CONNECTION

Each joist shall be attached to the beam in accordance with FIGURE 7 and the requirements below.

- Use Options 1 or 2 when joists bear on a dropped beam.
- Use Option 3 when joists bear at a flush beam; see SECTION 6 for hanger requirements.
- Mechanical fasteners or hurricane clips shall have a minimum capacity of 100 pounds in both uplift and lateral directions. Installation shall be per manufacturer's instructions.



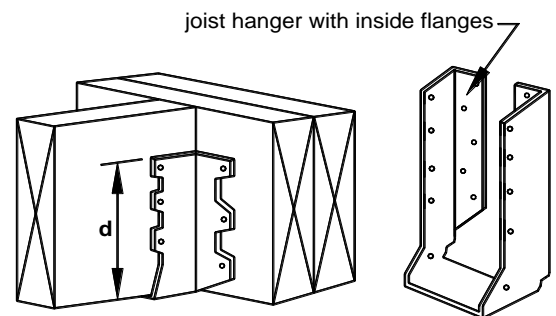
<sup>1</sup> Option 1 is prohibited on free-standing decks.

**FIGURE 7: JOIST-TO-BEAM CONNECTION**

## SECTION 6: JOIST HANGERS

Joist hangers shall meet the requirements listed below.

- Joist hanger depth (**d**, as shown in FIGURE 8) shall be greater than or equal to 60 percent of the joist depth.
- The manufactured width of the joist hanger shall accommodate the number of plies being carried.
- Do not bend hanger flanges to accommodate field conditions.
- Joist hangers shall be fastened to the ledger board using its manufacturer's recommended screws. All other fasteners are permitted to be nails.
- Use joist hangers with inside flanges when clearances to the edge of the beam or ledger board dictate.
- Clip angles or brackets used to support framing members in lieu of joist hangers are prohibited.



**FIGURE 8: JOIST HANGERS**

## SECTION 7: POSTS

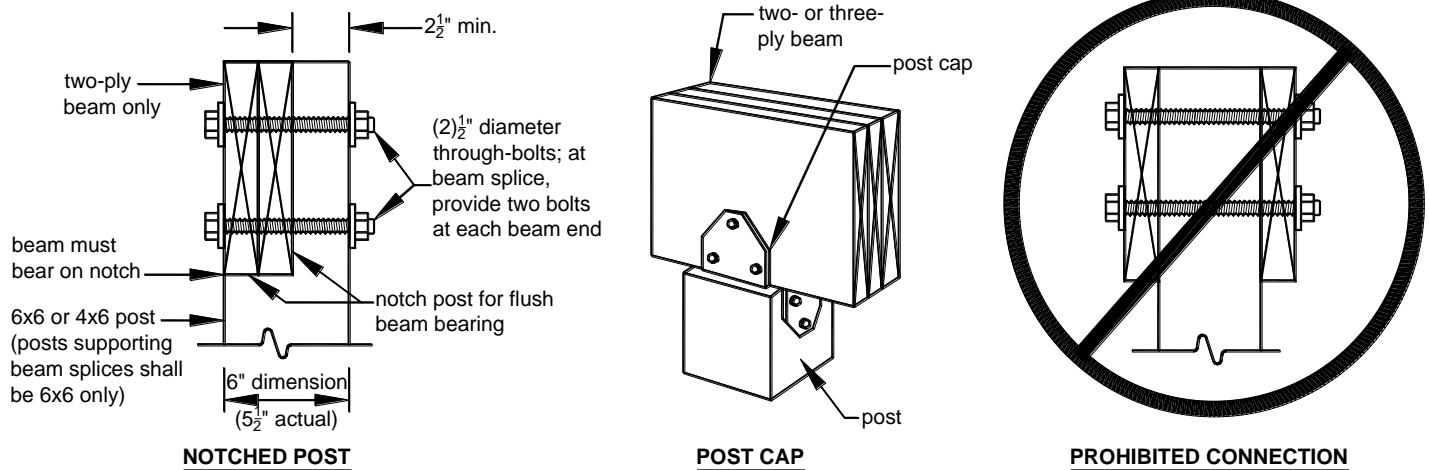
Posts shall meet the requirements listed below.

- Post height, measured from the top of the footing to the underside of the beam, shall be in accordance with TABLE 3.

**TABLE 3: MAXIMUM POST HEIGHT**

Post Size	Maximum Height
4x4	8'-0"
4x6	8'-0"
6x6	14'-0"

- Posts supporting a beam splice shall be 6x6 only.
- The beam shall be attached to the post by the appropriate methods shown in FIGURE 9.
- Post caps, as shown in FIGURE 9, shall be specifically designed for two- or three-ply beams and the post size used. Attachment shall be per manufacturer's instructions.
- Cut ends of posts shall be field treated with a wood preservative containing copper naphthenate. Such products can be found in the paint department of most hardware or home center stores.



**FIGURE 9: POST-TO-BEAM CONNECTIONS**

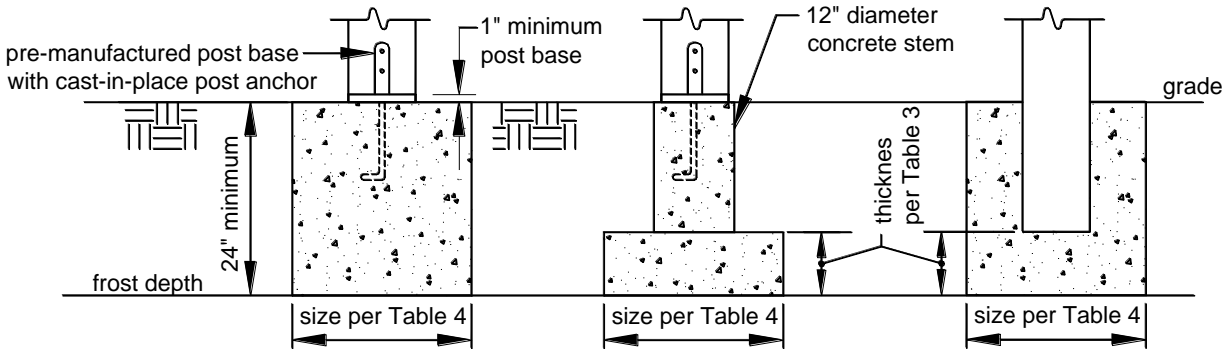
## SECTION 8: FOOTINGS

Footings shall be constructed in accordance with the requirements below.

- Concrete shall have a minimum compressive strength of 3,000 pounds per square inch.
- Footing size and thickness shall be in accordance with TABLE 4.
- Post attachment requirements shall be in accordance with FIGURE 10.
- Post anchors shall have a 1-inch minimum base.
- Posts shall be centered on the footing.
- Footings shall bear on solid ground at a minimum depth of 24 inches. Footings shall be deeper if solid ground is not found. Bearing conditions must be verified by county inspectors prior to placement of concrete.
- When the edge of a deck footing is closer than 5 feet to an existing exterior house wall, the footing must bear at the same elevation as the existing house footings.
- Do not construct footings over utility lines or service pipe. Call Miss Utility at 811 before you dig.

**TABLE 4: FOOTING SIZE**

Beam Span less than or equal to:	Joist Span less than or equal to:	Size of Square	Size of Round	Minimum Thickness
8'	10'	15"	17"	6"
	14'	18"	20"	8"
	18'	21"	23"	9"
12'	10'	19"	21"	8"
	14'	22"	24"	10"
	18'	26"	28"	11"
17'	10'	23"	25"	10"
	14'	28"	30"	12"



**FIGURE 10: FOOTINGS**

**SECTION 9: LEDGER ATTACHMENTS**

**General requirements.** Ledger boards shall be attached to the existing house in accordance with the requirements below. Compliance is critical to ensure the safety and structural stability of your deck.

- Ledger board depth shall be greater than or equal to the depth of the deck joists, but not less than a 2x8.
- The ledger board shall be attached in accordance with one of the conditions shown in FIGURES 12 through 14.
- The existing band board shall be capable of supporting the deck. If this cannot be verified or existing conditions differ from the details herein, then a free-standing deck or an engineered design is required.
- The top of the ledger board and top of the deck joists shall be at the same elevation.

**Wood I-joists.** Many homes are constructed with wood I-joists, as shown in FIGURE 11. Rather than utilize a 2x band board, these systems are often constructed with a minimum 1-inch thick engineered wood product (EWP) band board capable of supporting a deck. If a minimum 1-inch EWP or 2x band board is not present, then a free-standing deck is required; see Page 12 for more information.

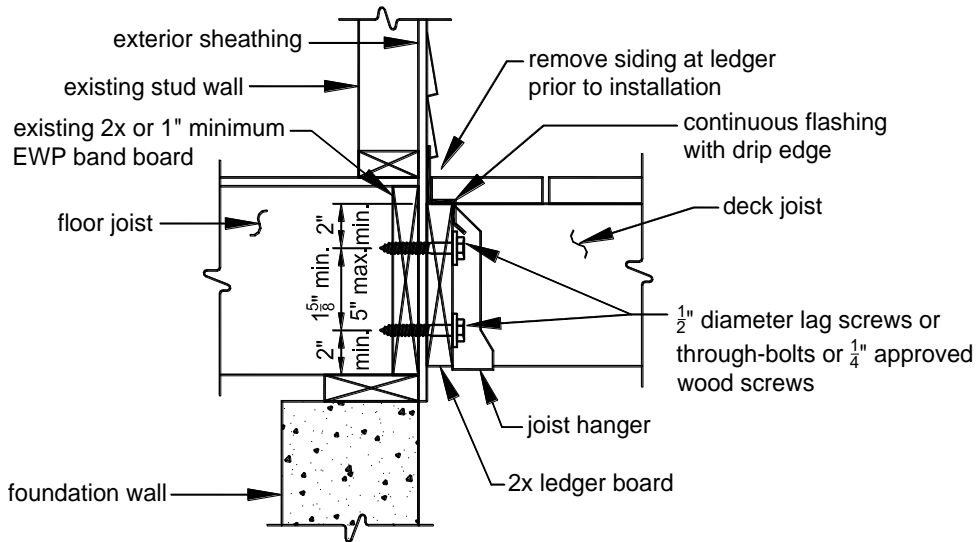


**FIGURE 11: WOOD I-JOISTS**

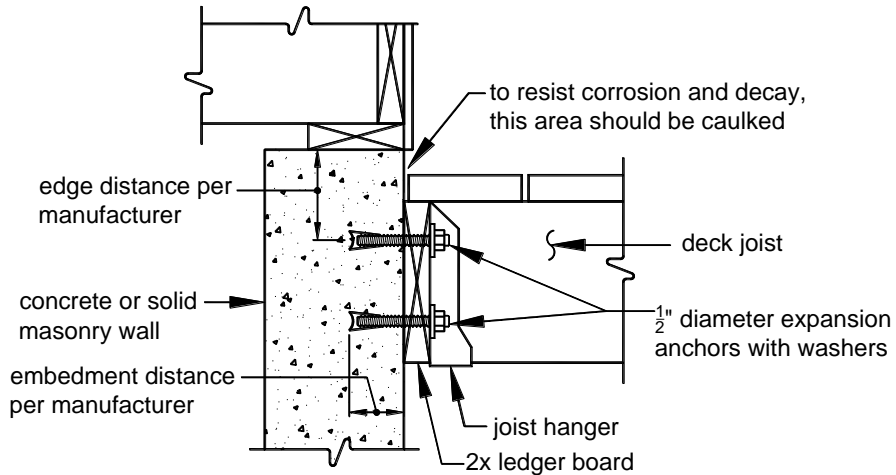
**Siding and flashing.** Flashing shall be installed in accordance with the requirements below.

- The exterior finish, i.e., house siding, must be removed prior to the installation of the ledger board.
- Continuous flashing with a drip edge, as shown in FIGURE 12, is required at the ledger board when attached to wood-framed construction.
- Flashing shall be copper (attached using copper nails only), stainless steel, UV resistant plastic or galvanized steel coated with 1.85 ounces of zinc per square foot (G-185 coating).
- Flashing at a door threshold shall be installed to prevent water intrusion from rain or melting snow.

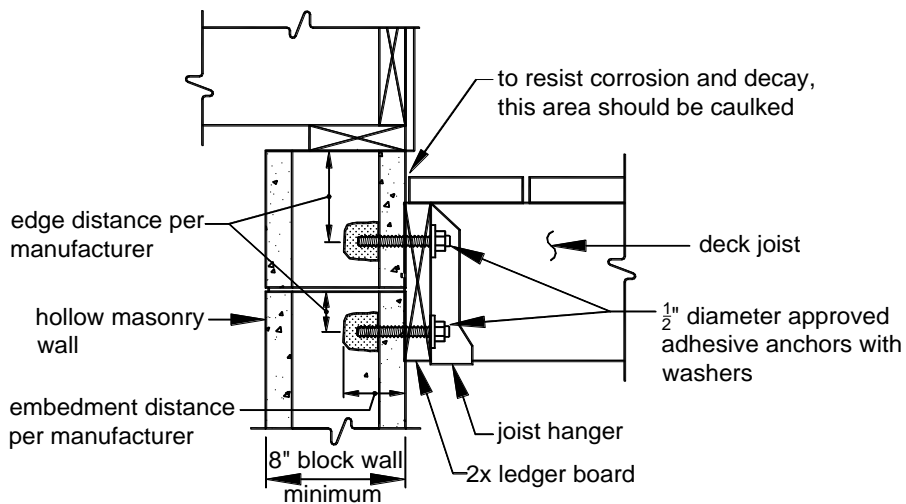




**FIGURE 12: LEDGER BOARD-TO-BAND BOARD ATTACHMENT**

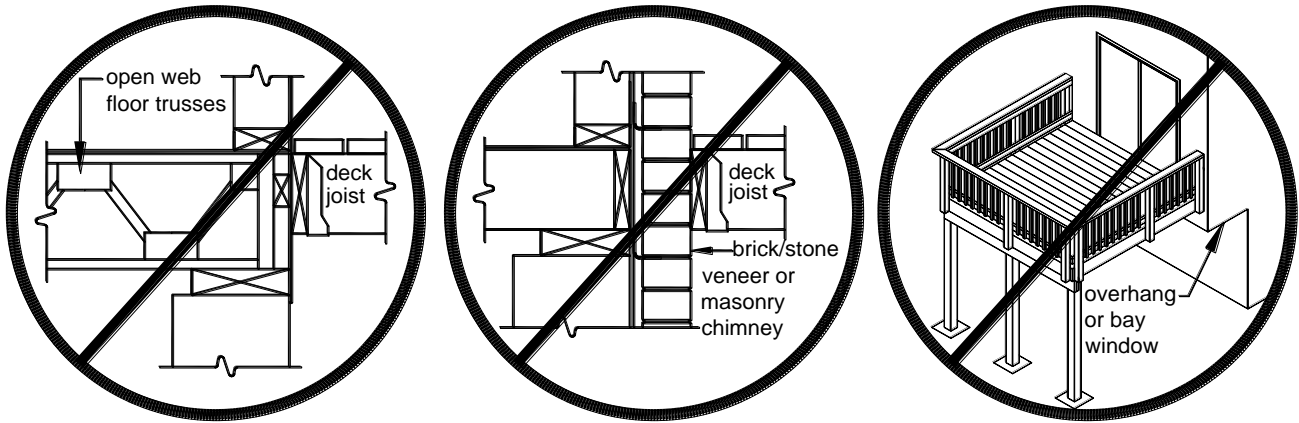


**FIGURE 13: LEDGER BOARD-TO-SOLID FOUNDATION ATTACHMENT**



**FIGURE 14: LEDGER BOARD-TO-HOLLOW FOUNDATION ATTACHMENT**

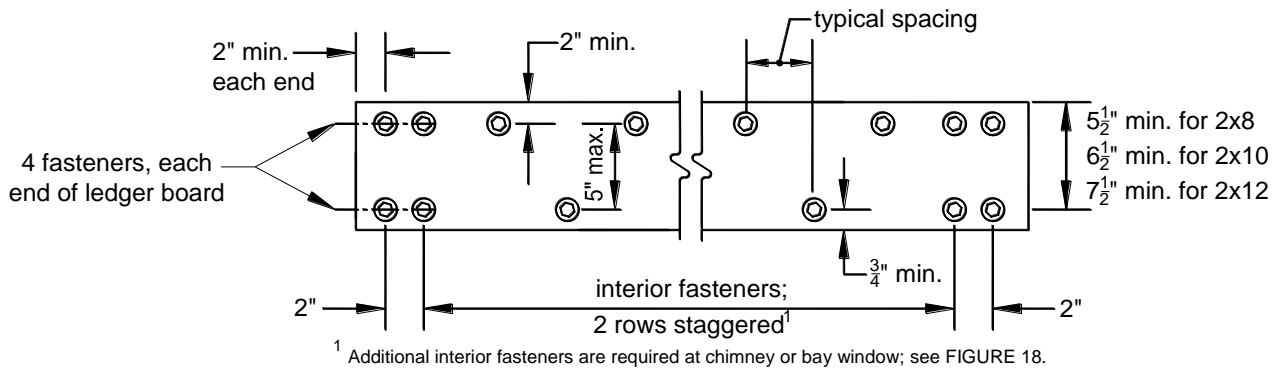
**Prohibited ledger attachments.** The ledger board attachment conditions shown below are prohibited. In such cases, the deck shall be free-standing; see Page 12.



**FIGURE 15: PROHIBITED LEDGER ATTACHMENTS**

**SECTION 10: LEDGER BOARD FASTENERS**

**General requirements.** Ledger board fasteners shall be installed in accordance with this section. Placement and spacing shall be in accordance with FIGURE 16 and TABLE 5. Only those fastener types noted herein are approved for use; lead anchors are prohibited. Adequacy of connections will be verified by county inspectors.



**FIGURE 16: LEDGER BOARD FASTENER SPACING AND CLEARANCES**

**TABLE 5: LEDGER BOARD FASTENER SPACING, ON CENTER**

Fastener	Band Board	Joist Span less than or equal to:						
		6'	8'	10'	12'	14'	16'	18'
Lag Screws	EWP <sup>1</sup>	24"	18"	14"	12"	10"	9"	8"
	2x lumber	30"	23"	18"	15"	13"	11"	10"
Through Bolts	EWP <sup>1</sup>	24"	18"	14"	12"	10"	9"	8"
	2x lumber	36"	36"	34"	29"	24"	21"	19"
Wood Screws <sup>2</sup>	1" EWP <sup>1</sup>	18"	13"	11"	9"	8"	7"	6"
	2x lumber	19"	14"	11"	9"	8"	7"	6"
Expansion Anchors	—	36"	36"	34"	29"	24"	21"	19"
Adhesive Anchors	—	32"	32"	32"	24"	24"	16"	16"

<sup>1</sup> EWP = 1" minimum manufactured engineered wood product; see Page 8 for more information.

<sup>2</sup> Wood screws shall be permitted to be spaced in accordance with its corresponding evaluation report if less restrictive than the values in TABLE 5.

**Through-bolts.** Through-bolts shall have a minimum ½-inch diameter. Pilot holes for through-bolts shall be 17/32 to 9/16 inches in diameter. Through-bolts must be equipped with washers at the bolt-head and nut. Bolts should be tightened six to 12 months after construction due to drying and wood shrinkage.

**Expansion anchors.** Expansion anchors shall be used only when attaching a ledger board to a concrete or solid masonry wall as shown in FIGURE 13. The bolt or threaded rod of expansion anchors shall have a ½-inch diameter minimum; in some cases, this may require a 5/8-inch anchor size. Expansion anchors must be installed per manufacturer's instructions and shall be equipped with washers.

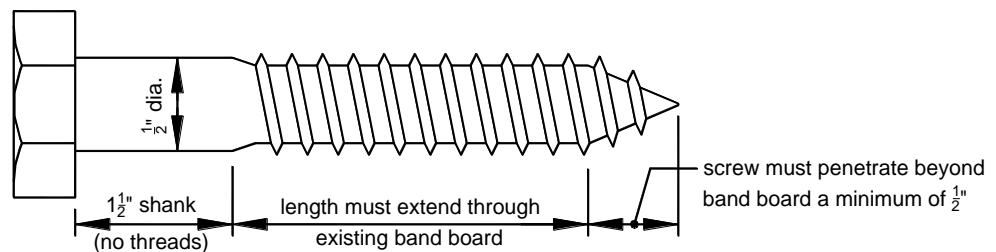
**Adhesive anchors.** The adhesive anchors listed in TABLE 6 with a minimum ½-inch diameter threaded rod shall be used when attaching to hollow masonry as shown in FIGURE 14. Adhesive anchors are also permitted with concrete or solid masonry installations. Anchors shall be installed per manufacturer's instructions and shall be equipped with washers. Adhesive cartridges must be remain on the jobsite for inspector verification.

**TABLE 6: APPROVED ADHESIVE ANCHORS**

Manufacturer	Product
ITW Ramset/Red Head	Epcon Acrylic 7
Hilti	HY-20

**Lag screws.** Lag screws shall be hot-dipped galvanized or stainless steel with a ½-inch minimum diameter. Length and shank requirements shall be in accordance with FIGURE 17. Lag screws shall be equipped with washers and installed in the sequence below.

1. Drill a ½-inch diameter hole in the ledger board and a 5/16-inch diameter pilot-hole into the solid connection material of the existing house.
2. Insert the lag screw through the ledger board and into the pilot hole by turning. Do not drive with a hammer. Use soap or a wood-compatible lubricant as required to facilitate tightening.
3. Tighten each lag screw snugly, but do not over tighten so as to cause wood damage.



**FIGURE 17: LAG SCREW**

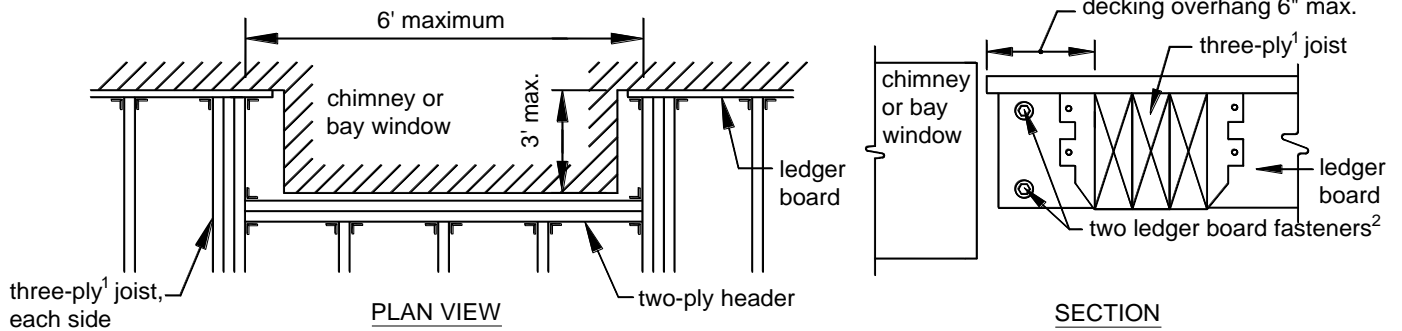
**Wood screws.** The wood screws listed in TABLE 7 with a ¼-inch diameter may be used to attach to wood-framed construction. Wood screws shall have a sufficient length to fully penetrate the existing house band board. Installation shall be in conformance with the manufacturer's instructions.

**TABLE 7: APPROVED WOOD SCREWS**

Manufacturer	Product
FastenMaster	LedgerLok
Simpson Strong-Tie	Strong-Drive Screws (SDS, SDW)

## SECTION 11: FRAMING AT CHIMNEY OR BAY WINDOW

Additional framing and ledger board fasteners at a chimney or bay window protrusion are required as shown in FIGURE 18. Each ply of the header shall be equal to the deck joist size. Joist hangers shall meet the requirements on Page 6.



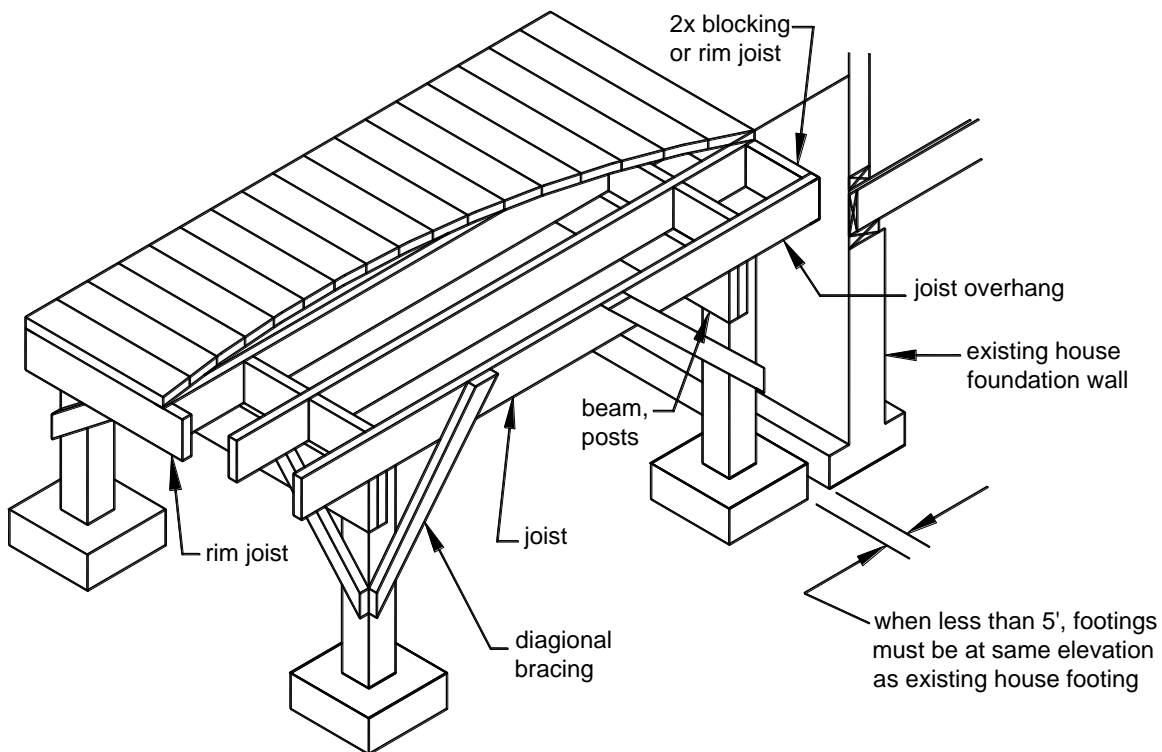
<sup>1</sup> May be reduce to two-ply if joist spacing = 24" on center or joist span ≤ 8'-6".

<sup>2</sup> Fasteners adjacent chimney/bay window are considered interior to the ledger board. See FIGURE 16 for fasteners requirements at the end of the ledger board.

**FIGURE 18: FRAMING AT CHIMNEY OR BAY WINDOW**

## SECTION 12: FREE-STANDING DECKS

Decks which are free-standing do not utilize the exterior wall of the existing house to support vertical or horizontal loads. An additional beam is provided at or offset from the existing house wall; see FIGURES 4 and 19. When the edge of a deck footing is closer than 5 feet to an existing exterior house wall, the footing must bear at the same elevation as the existing house footings as shown in FIGURE 19 below. Beam size is determined by TABLE 2.



**FIGURE 19: FREE-STANDING DECK**

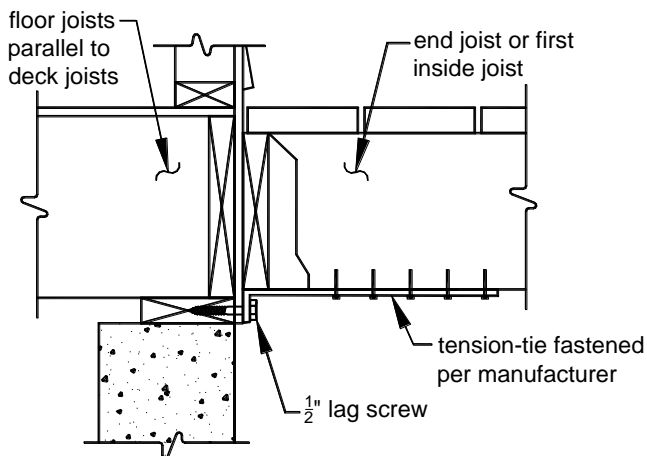
All decks greater than 30 inches above grade must resist lateral load using one of the applicable methods noted below.

### Method 1) Tension-ties:

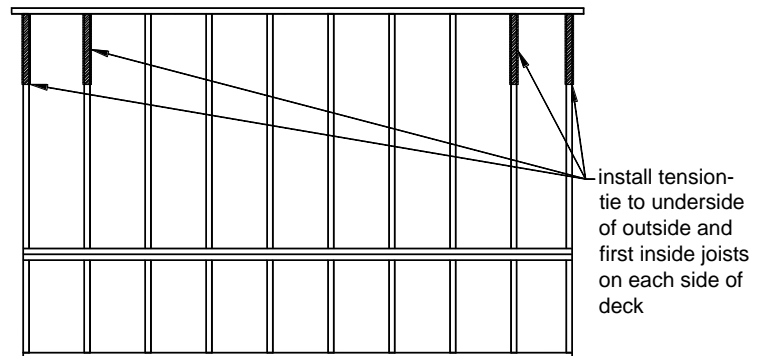
- This method is not permitted for free-standing decks.
- This method is permitted only where the deck joists and floor joists are parallel as shown in FIGURE 21.
- Tension-ties (four total) shall be installed at the end joist and first inside joist at each end of the deck as shown in FIGURE 22. A set of tension-ties shall be installed for each structurally independent section of a multi-level deck.
- Approved tension-ties include: LTS19 from USP or LTT19 from Simpson Strong-Tie; see FIGURE 20.
- The minimum capacity of each tension-tie shall be 750 pounds.
- Tension ties are not available in a G-185 zinc coating. Therefore, a barrier membrane must separate the tension tie and the preservative-treated joist. The barrier membrane Vycor Deck Protector or an equivalent are permitted.
- Tension-ties shall be attached to the underside of the joists per the manufacturer's instructions. Tension-ties shall be attached to the exterior wall with lag screws as shown in FIGURE 21. Lag screws shall penetrate a minimum of 3 inches into the sill plate or top plate of a wood framed wall.
- Where attaching to a concrete wall, lags screws are permitted to be substituted with adhesive anchors with a ½-inch threaded rod and a withdrawal capacity of at least 750 pounds. The anchor shall be installed per manufacturer.



**FIGURE 20:  
TENSION-TIE**



**FIGURE 21: TENSION-TIE CONNECTION**

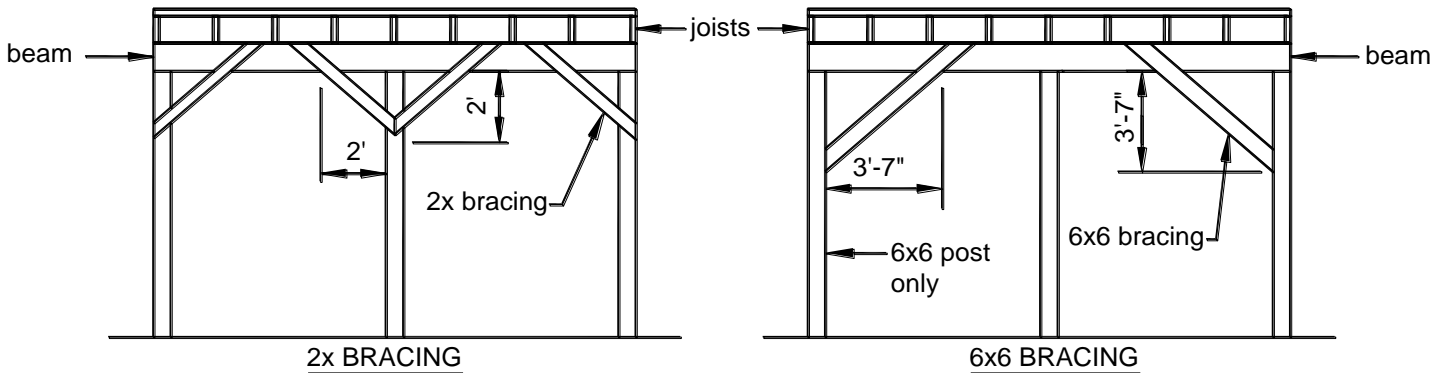


**FIGURE 22: TENSION TIE LOCATIONS  
ON UNDERSIDE OF DECK JOISTS**

### Method 2) Diagonal bracing:

- Diagonal bracing shall be 2x members at any post size or 6x6 members at 6x6 posts only.
- Decks shall have diagonal bracing installed at the post-beam locations noted in FIGURE 23.
- Free-standing decks shall also have diagonal bracing installed at each post-joist location in accordance with FIGURE 24.
- Connections of diagonal bracing shall be in accordance with FIGURES 25 and 26.

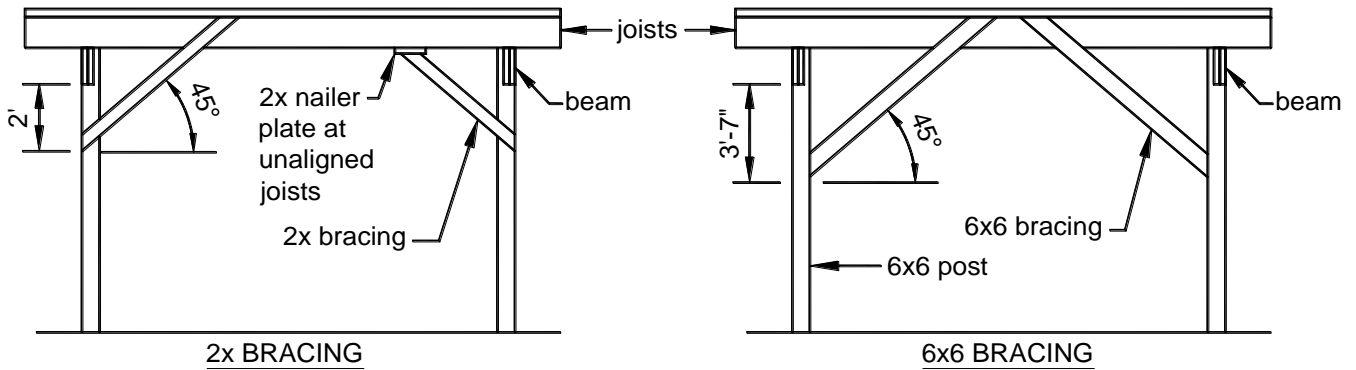
- For decks attached to the existing house, the ratio of the overall deck length to width must be no more than 2 to 1. This requirement can also be verified by ensuring  $L \div W \leq 2$  as shown in FIGURE 41. (This does not apply to free-standing decks or attached decks using lateral support Method 1.)



- Place 2x bracing at all beam-post locations.
- Alternate bracing between front and back of 4x4 or 4x6 posts.

- Permitted at 6x6 post locations only.
- Place 6x6 bracing at end posts and on both sides of every other interior post.

**FIGURE 23: DIAGONAL BRACING AT BEAM-POST LOCATIONS**

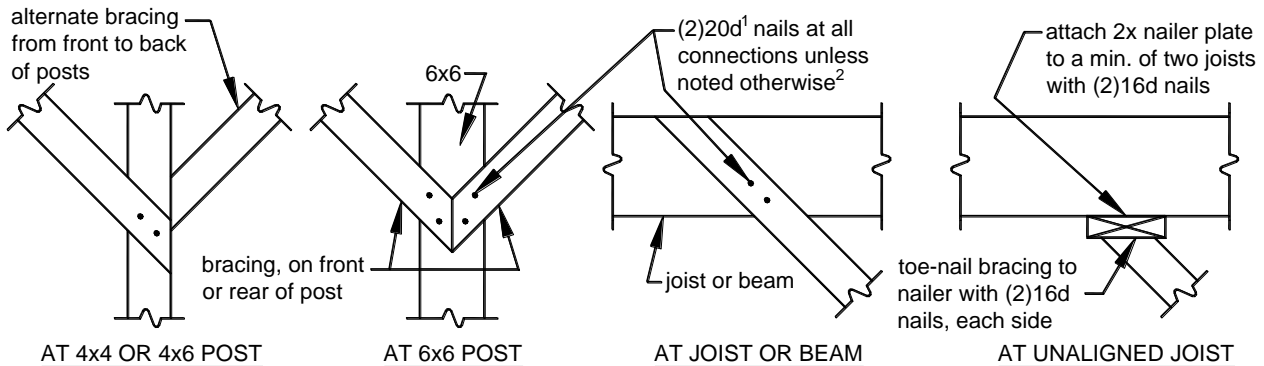


- Place 2x bracing at all joist-post locations.
- Where bracing does not align with a joist, provide 2x nailer plate.

- Permitted at 6x6 post locations only.
- At unaligned joists, notch or add blocking as necessary to accommodate connection.

**FIGURE 24: DIAGONAL BRACING AT JOIST-POST LOCATIONS**

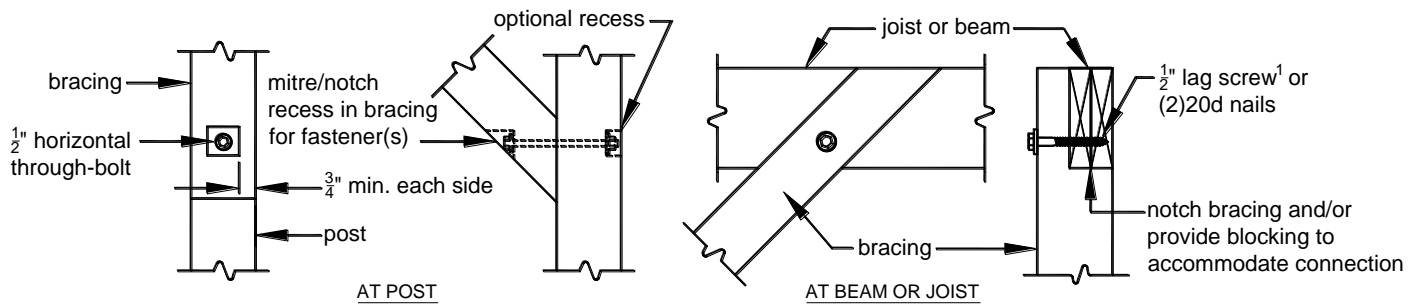
(required for free-standing decks only)



<sup>1</sup> Nails may be substituted with an equal number of the approved wood screws listed in TABLE 7.

<sup>2</sup> Nails shall have a distance of  $\frac{3}{8}$  inches to all edges and  $\frac{1}{4}$  inches to the end of the bracing member.

**FIGURE 25: TYPICAL CONNECTIONS OF 2x BRACING**



<sup>1</sup> Lag screw may be substituted with two approved wood screws as listed in TABLE 7.

**FIGURE 26: TYPICAL CONNECTIONS OF 6x6 BRACING**

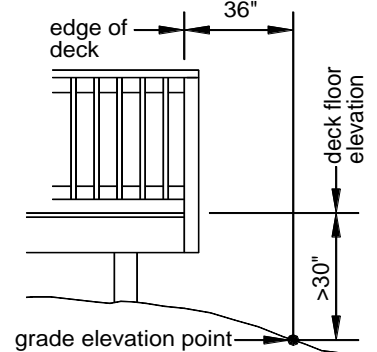
**SECTION 14: GUARDS**

**General requirements.** A guard is required when a deck is greater than 30 inches above grade at a point 36 inches from the edge of the deck, as shown in FIGURE 27. Guards shall be constructed in accordance with the requirements herein; deviations are prohibited. Guards which are not required, but are nevertheless provided, must also comply with these requirements.

**Wood-plastic composites.** Wood-plastic composites of equal dimension and complying with the criteria noted on Page 3 may be substituted for the guard rail-cap and infill elements shown in FIGURE 29 provided the manufacturer’s performance criteria specifically permit such use.

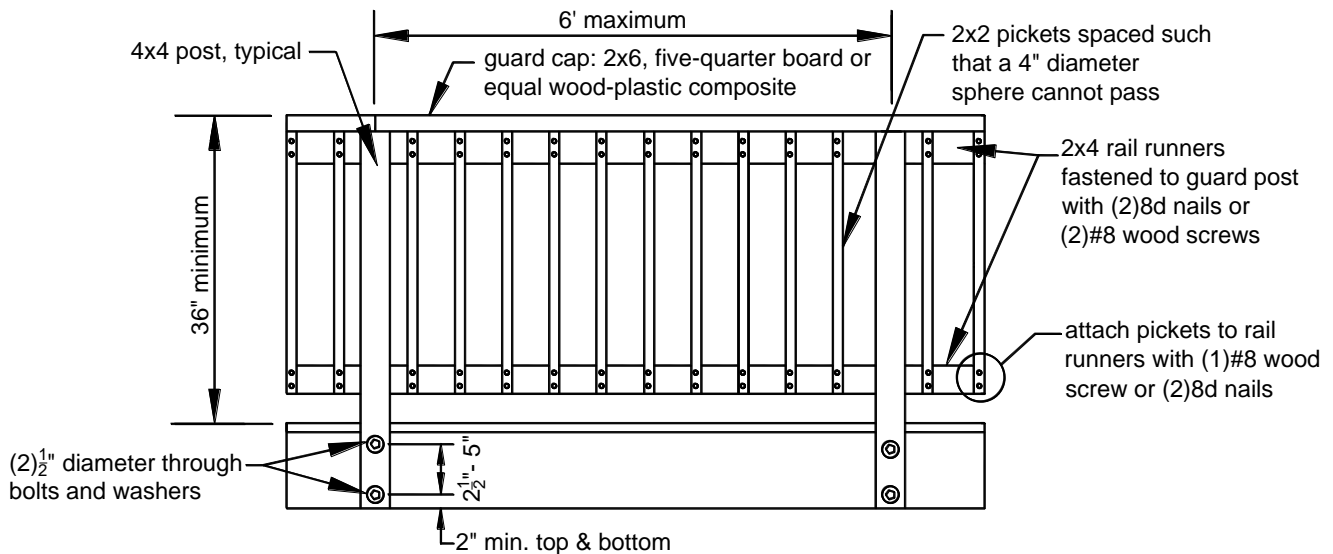
**Guard systems.** Guard systems with a valid evaluation report from an accredited listing agency are permitted. See FIGURE 28 for a sample report. For a list of approved systems, go to [fairfaxcounty.gov](http://fairfaxcounty.gov) and search on “structural plastics.” Pre-fabricated systems without an evaluation report will require a plan review during the permit application process.

**Openings in guards.** Guards shall be constructed to restrict the passage of a 4-inch diameter sphere through any opening. Wet lumber shall be spaced such that when shrinkage occurs, a compliant opening is maintained.



**FIGURE 27: WHEN A GUARD IS REQUIRED**

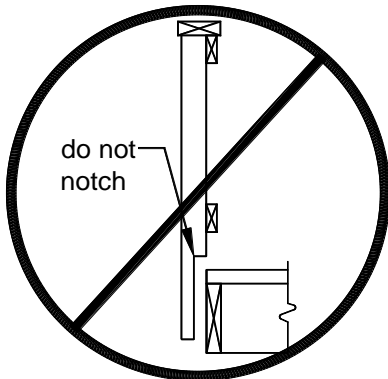
**FIGURE 28: EVALUATION REPORT**



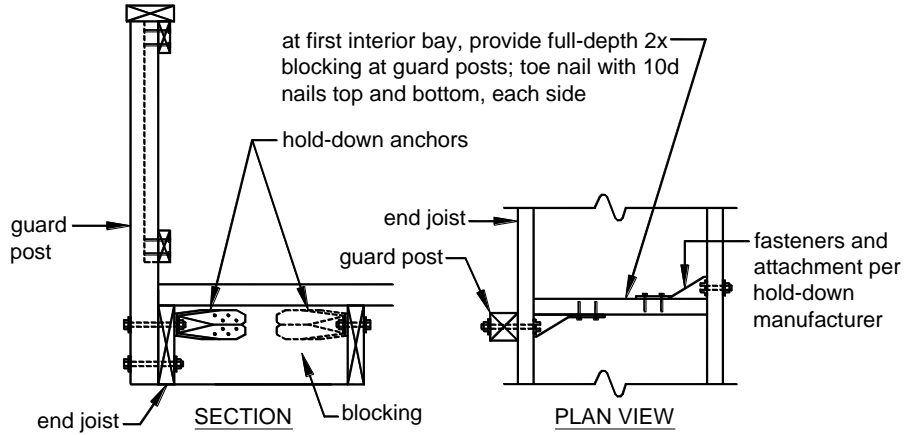
**FIGURE 29: GUARDS**

**Guard posts.** Guard posts shall be attached to the deck structure in accordance with the requirements below in order to ensure resistance to imposed loads.

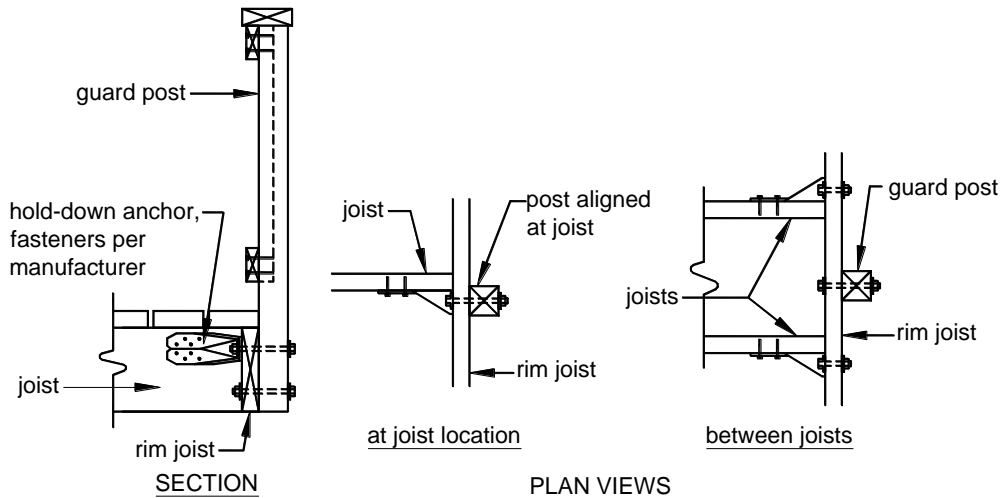
- Notching guard posts, as shown in FIGURE 30, is prohibited.
- Hold-down anchors, as shown in FIGURES 31 and 32, shall be used to attach the guard post to the end joist and rim joist, respectively.
- Hold-down anchors shall have a minimum capacity of 1,800 pounds.
- Guard posts may be attached to either side of the rim joist or end joist.



**FIGURE 30: POST NOTCHES PROHIBITED**



**FIGURE 31: GUARD POST-TO-END JOIST**



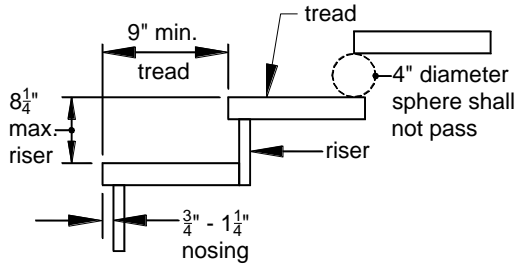
**FIGURE 32: GUARD POST-TO-RIM JOIST**

**SECTION 15: STAIRS**

**Stair dimensions.** Stairs shall be constructed with the dimensions listed below.

- The minimum width of a stairway is 36 inches.
- Stair geometry and opening limitations shall meet the requirements shown in FIGURE 33. Treads, risers and nosing dimensions shall not deviate at each step by more than 3/8 inch.
- If the total vertical height of a stairway exceeds 12 feet, then an intermediate landing is required and must be constructed as a free-standing deck with flush beams.
- Landing widths shall be equal to the total width(s) of the stairway(s) it serves.





**Stair stringers.** Stringers shall be in accordance with the following requirements.

- Stringers shall be sawn or solid 2x12s complying with the tread and riser geometry requirements.
- Stringers shall be spaced at a maximum of 18 inches on center.
- Stringers shall bear on footings and attach to the deck or landing per FIGURE 34.
- Stringer span length is measured using the horizontally projected distance between the centerlines of bearing at each end.
- The span length of a stringer shall not exceed 6 feet-11 inches, and the throat size of cut stringers shall not exceed 5 inches as shown in FIGURE 35.

**Solid stringer exception:** Stringers of stairways with a width equal to 36 inches shall be permitted to have a horizontally projected span up to 15.5 feet when framed solely with two solid stringers.

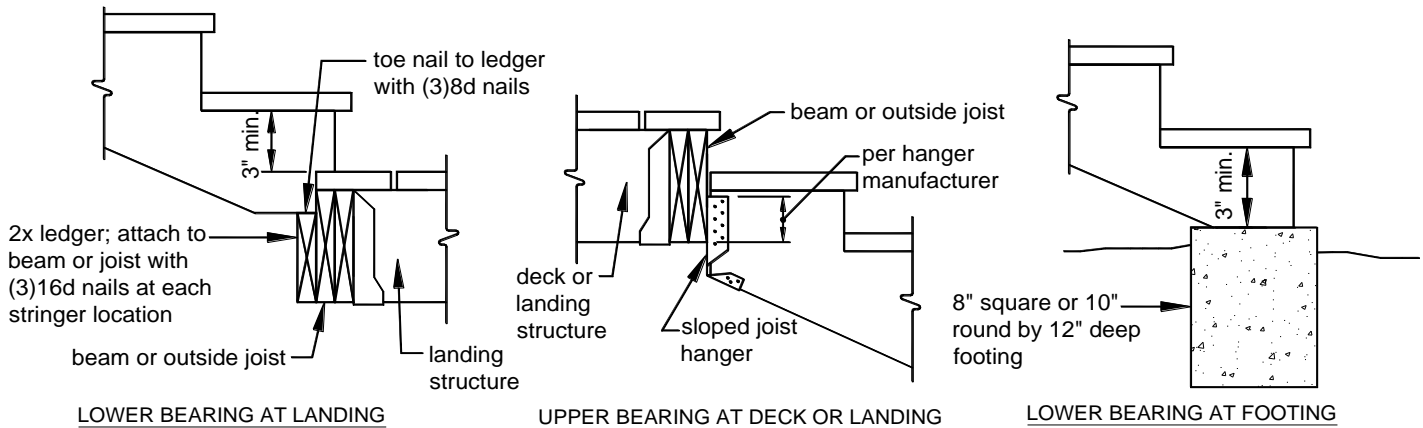


FIGURE 34: STRINGER BEARING

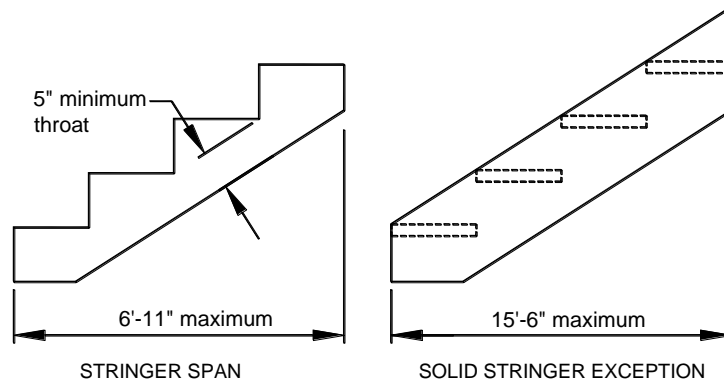
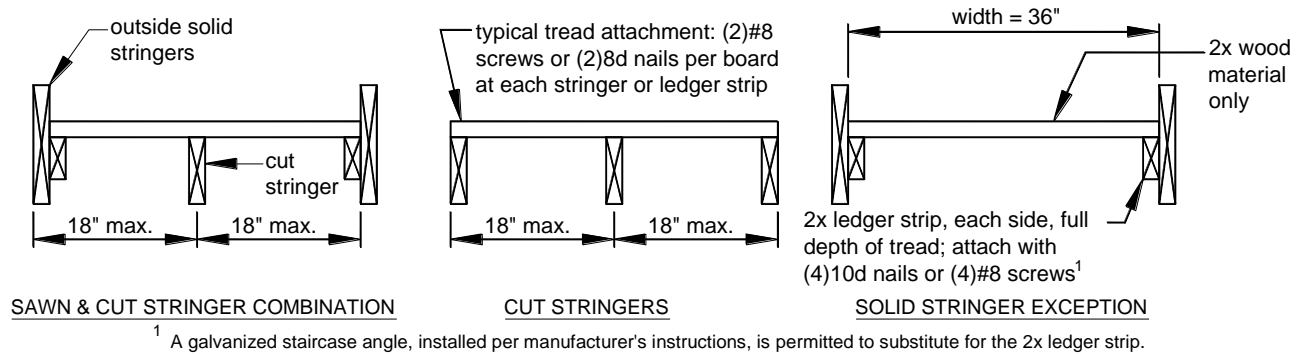


FIGURE 35: MAXIMUM STRINGER SPAN LENGTH

**Tread and riser material.** Tread and riser material shall be in accordance with the requirements below.

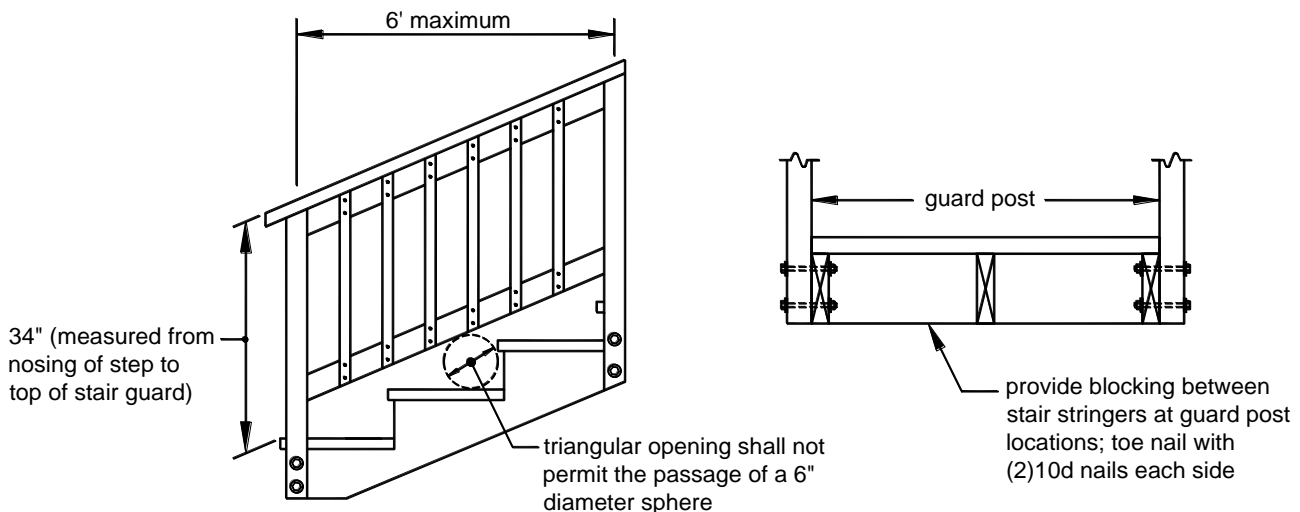
- Tread material shall be equivalent to the decking specified on Page 3 and attached in accordance with FIGURE 36.

- Stairs constructed using the solid stringer exception noted above shall have treads constructed of 2x wood material only; see FIGURE 36.
- Risers may be framed with 1x lumber minimum or equivalent wood-plastic composite. Open risers are permitted provided the opening does not allow the passage of a 4-inch diameter sphere.



**FIGURE 36: STRINGER TREADS**

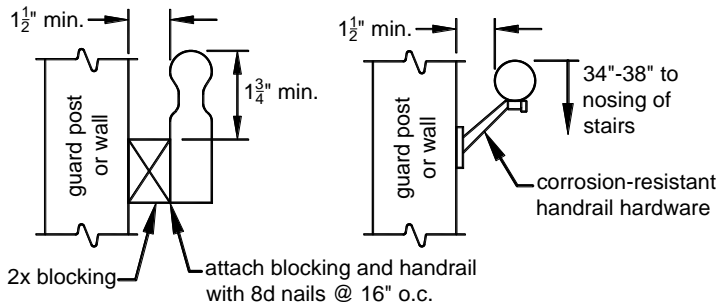
**Stair guards.** Stair guards shall be required when the total rise of the stair is greater than 30 inches at a point 36 inches from the edge of the stair. Stair guards shall be constructed in accordance with SECTION 14 and FIGURE 37.



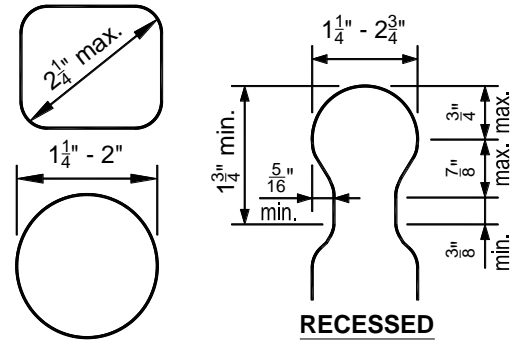
**FIGURE 37: STAIR GUARD**

**Stair handrails.** Handrails shall be provided in accordance with the following requirements.

- Stairs with four or more risers shall have a handrail on one side at a height between 34 to 38 inches above the nosing of the step.
- Handrails shall be attached to a stair guard or exterior wall acting as a barrier as shown in see FIGURE 38.
- Handrail and connecting hardware material shall be decay and corrosion resistant.
- Handrails shall have a smooth surface with no sharp corners and shall be graspable. Recessed sections may be shaped from a 2x6 or five-quarter board as shown in FIGURE 39.
- Handrails shall run continuously from a point directly over the lowest riser to a point directly over the highest riser and shall return to the guard or wall at each end.
- Handrails may be interrupted by guard posts at a turn in the stair only.



**FIGURE 38: HANDRAILS**



**FIGURE 39: HANDRAIL GRASPABILITY**

**Stair lighting.** Each stairway section shall have a light source at the top such that all stairs and landings are illuminated. Lights shall be operated from switches inside the house, motion detectors or timed switches.

**SECTION 16: SAFETY GLAZING**

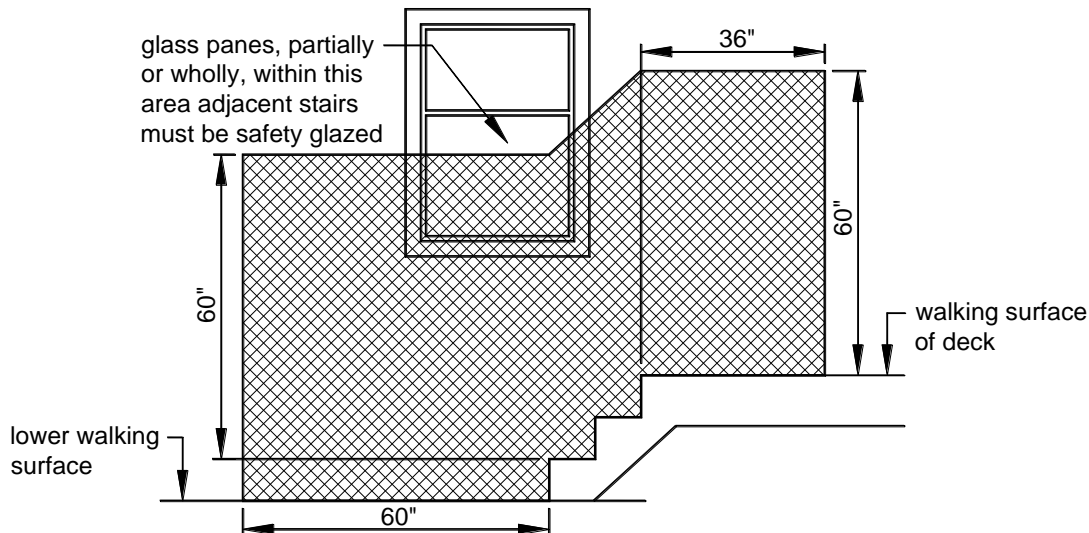
**General requirements.** To reduce injury due to an accidental impact, safety glazing in window and door glass is required when the existing house wall encloses any portion of the deck or acts as a barrier to stairs, landings and areas at the top and bottom of the stairs.

**Window adjacent any surface of a deck.** Individual panes of glass meeting all the requirements listed below must be safety-glazed.

- Glass area is greater than 9 square feet,
- The bottom edge of the pane is less than 18 inches above the walking surface of the deck, and
- The top edge of the pane is greater than 36 inches above the walking surface of the deck.

In the absence of safety glazing, a horizontal rail across the window must be installed at a height between 34 and 38 inches. The rail must meet the requirements of a stair handrail.

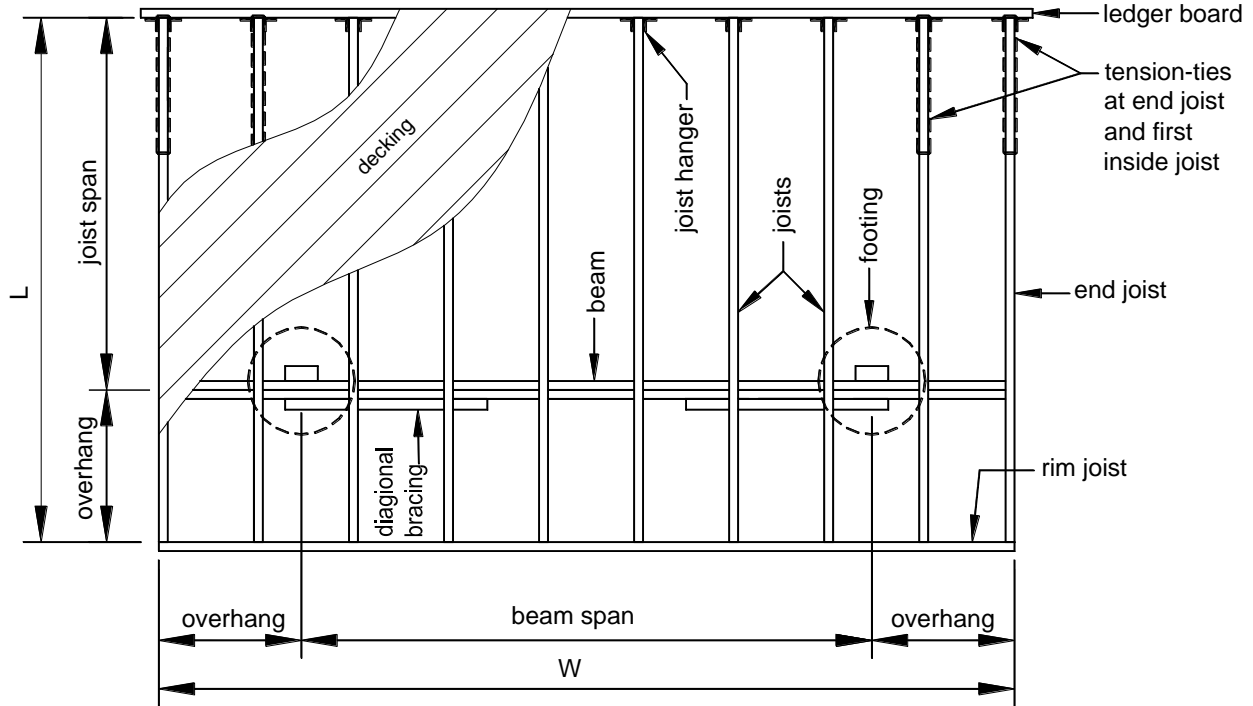
**Windows adjacent stairway.** Individual panes, partially or wholly located in the hatched area shown in FIGURE 40, must be safety-glazed. In the absence of safety glazing in a window adjacent a stairway, a stair guard must be constructed to separate the window from the stairway. In the absence of safety glazing in a window adjacent the 36-inch horizontal areas at the top or bottom of the stairs, a guard or horizontal rail must be installed at a height between 34 and 38 inches. The rail must meet the requirements of a stair handrail.



**FIGURE 40: SAFETY GLAZING AREA AT STAIRS**

**SECTION 17: COMPLETE YOUR DECK**

**Complete Your Deck:** A framing plan shows a bird's-eye view of the joist and beam layout, the location of the ledger board, diagonal bracing or hold-down devices, posts, footings, and the type, size and spacing of the ledger board fasteners. Use the sample typical deck framing plan shown below and the requirements of this document to complete your deck.



**FIGURE 41: TYPICAL DECK FRAMING PLAN**

**Decking:**  2x4  2x6  five-quarter board  wood-plastic composite (per ASTM D 7032)  
 Other/plastic decking, evaluation report number: \_\_\_\_\_

**Joists:** size:  2x6  2x8  2x10  2x12 spacing:  12 in.  16 in.  24 in.  
 joist span dimension: \_\_\_\_\_ ft. - \_\_\_\_\_ in.  
 overhang:  Yes  No overhang dimension: \_\_\_\_\_ ft. - \_\_\_\_\_ in.  
 rim joist:  2x6  2x8  2x10  2x12

**Beam(s):** number of plies:  2  3 size:  2x6  2x8  2x10  2x12  
 overhang:  Yes  No overhang dimension: \_\_\_\_\_ ft. - \_\_\_\_\_ in.

**Posts:** size:  4x4  4x6  6x6 height: \_\_\_\_\_ ft. - \_\_\_\_\_ in.

**Footings:** size: \_\_\_\_\_ in.  square  round thickness: \_\_\_\_\_ in.

**Ledger:** ledger board size:  2x8  2x10  2x12  Not applicable (free-standing deck)  
 fastener:  Through bolt  Lag screw  
 Expansion anchor  Adhesive anchor  
 Wood screw

**Lateral support:**  Tension-tie  Diagonal bracing, size:  2x  6x6  
 (not permitted for free-standing deck)

**Deck size:** L= \_\_\_\_\_ ft. - \_\_\_\_\_ in. W= \_\_\_\_\_ ft. - \_\_\_\_\_ in.  $\frac{L}{W} = \underline{\hspace{1cm}} \leq 2.0$  (for attached decks with diagonal bracing only)